



HYDRAULIK



Solutions
in motion



**TELESCOPIC – HOLELESS
INSTALLATION GUIDE**

SOLUTIONS
in motions

Product **presentation**

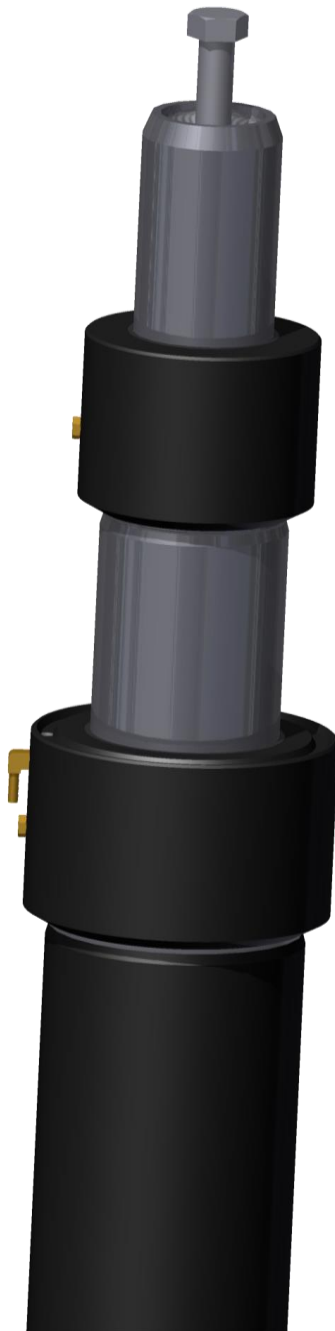

2

Holeless telescopic jack

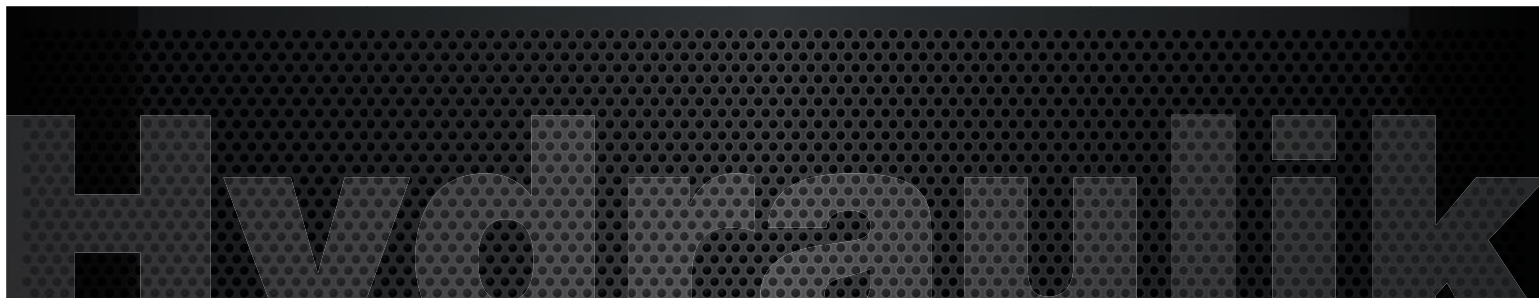

Tables of **contents**

Product presentation	2
Technical drawing – Head	4
Technical drawing – Bottom	5
Product characteristics	6
Holeless telescopic jack installation	7
Air bleeding	9
Followers guides	10
Twin jacks	11
Maintenance program	12
Check valve replacement	13
Warranty policy	15-16

Technical drawing – **Head**

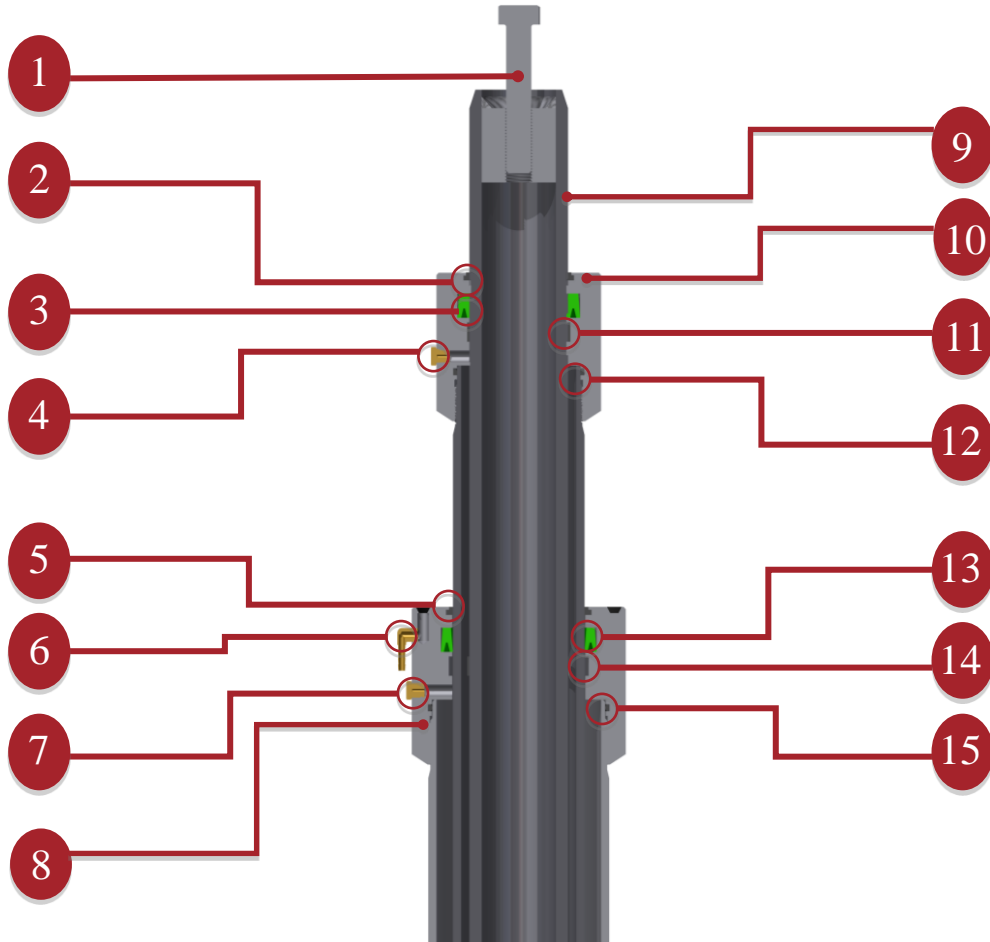

#	Components	Materials
1	Bolt	Steel
2	Wiper (1 st section)	Urethane
3	Seal (1 st section)	Urethane
4	Bleeder (1 st section)	-
5	Wiper (2 nd section)	Urethane
6	90° coupling (2 nd section)	-
7	Bleeder (2 nd section)	-
8	Head (1 st section)	Cast iron

#	Components	Materials
9	Tube or shaft (1 st section)	Steel
10	Head (2 nd section)	Cast iron
11	Wear ring (1 st section)	Nylon
12	O'ring (1 st section)	Buna-N
13	Seal (2 nd section)	Urethane
14	Wear ring (2 nd section)	Nylon
15	O'ring (2 nd section)	Buna-N

If more than 2 sections, the components of the first section repeat for the additional sections.

Technical drawing – **Bottom**

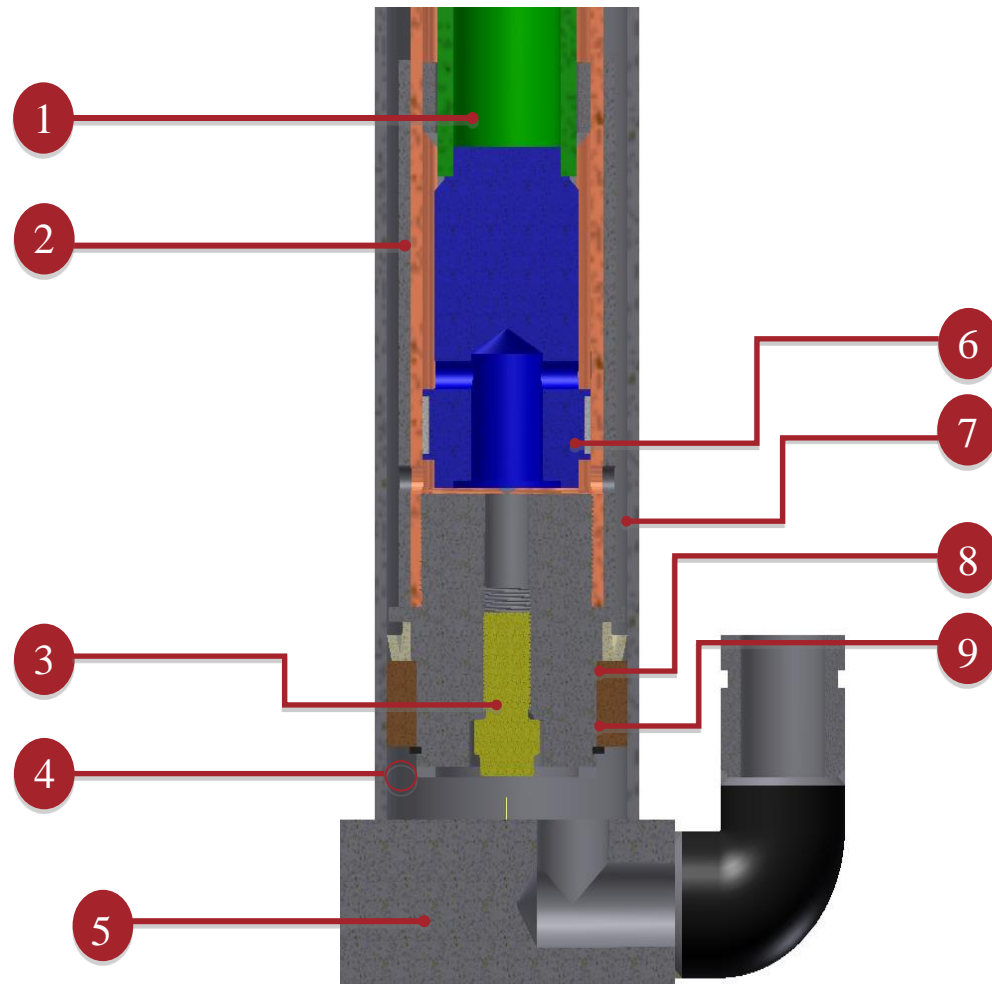

#	Components	Materials
1	Piston	Cast iron
2	2 nd (or last) section	Steel
3	Check valve	Steel
4	Spirolock	Steel
5	Base	Steel

#	Components	Materials
6	Wear ring	Plastic
7	Casing	Steel
8	Seal	Urethane
9	Bronze piston	Bronze

Product **characteristics**

Capacity & standard dimensions

Capacity

Up to 50 000 lbs

1st section

From 1 1/2" to 8"

Number of sections

From 2 to 4

Note *Non-standard sizes are available upon request.*

Fabrication

Conception and fabrication of the products are in accordance with the CSA B44-13 and ASTM A17.1-2013 standards.

Our welding procedures are certified according to the CSA W47.1 standard by the Canadian Welding Bureau (CWB).

Scope

- Dumb-waiter lifts
- Lift for disabled people
- Any other utilisation to suit your needs

Further information

Our cylinders are perfectly adapted to any type of elevator (passenger or merchandise).

This cylinder is proudly made in Quebec (Canada) or South Carolina (United States). It can be delivered to the destination of your choice, anywhere in the world.

Holeless telescopic jack **installation**

Hardware

For the cylinder installation

- 1 x Air bleeder (1/8" NPT)
- 1 x Straight coupling for oil return (1/8" NPT)
- 1 x 90° coupling for oil return (1/8" NPT)
- 1 x Clear tubing $\varnothing 3/8"$, 8' longer than the closed length
- 1 x Roll of Teflon tape

Tools

- Buffers
- Bolts

Holeless telescopic cylinder alignment

1. Temporarily locate the jack's support plate on the pit floor through the centerline of the mounting plate, under the car.
2. Position the jack on the pit support plate, plumb the jack with a level and fix a clamp on the wall of the jack close to the head.
3. Set the plumb line off the rails in the hoist way through the centerline of the platen plate under the car, at the highest possible point.
4. Adjust the wall clamp, so the jack will be centered on the plumb line.
5. Plug the hydraulic feed line to the jack. When installing the telescopic jack, the oil supply line should be connected as quickly as possible to reduce the loss of pre-filled oil.
6. Raise the jack to approximately half the travel and, using plumb line, check that the jack stays on the same centerline as the mounting plate, under the car.

7. Make final adjustments to the pit support plate if the jack is slightly out of plumb.
8. For safety reasons it is advisable, and in some mandatory, to install a line rupture valve at the inlet port of the jack when a hose is used as the inlet line.
9. It will be necessary to bleed air from each stage through the air bleeder valve located on each head.

It is important that the actual site conditions are as specified on the layout drawing. Before leaving the job, ensure the total under travel and over travel ratios are specified. Any discrepancy should be noted and corrected before shipping the lift to the customer.

Any small scratches visible on the stages should be polished with very smooth emery (400 grit).

Air bleeding

To assure proper functioning of the jack, it is important to take any air out of it by applying the following procedure:

1. Remove the “Spring Buffers”.
2. Lower the car (if already installed) so the jack is completely retracted. Always be sure that the cylinder remains completely retracted.
3. Adjust the safety valve (BPS) (on the control valve of the power unit) from 25 to 50 PSI, so that the system is pressurized without lifting the car.
4. If the minimum of 25 to 50 psi can't be reach, you can manually open the valve and add more BPS.
5. Open the bleeder purge valve of the top section.
6. Start the pumping unit and shut it down as soon as there is no more air coming out of the bleeder. Close the bleeder to prevent unnecessary oil loss.
7. Repeat these two steps for each section, beginning with the top one and finishing with the lowest.
8. Run the cylinder about 5 complete strokes, both extension and retraction, to be sure of its proper functioning.
9. Repeat steps 2 to 6 to verify that there is no air in the cylinder.

If two people are bleeding the jack, it is possible to open all the bleeders at one since one person stays at the power unit whereas the other closes the bleeder. A mechanic alone will have to bleed the sections one at a time.

It is possible that at some point your telescopic cylinder is desynchronized. Desynchronization may be caused by leaking seals or a malfunction of the check valve. The venting procedure can resynchronize the telescopic cylinder since it "resets" the distribution of oil volumes between the sections.

Followers **guides**

Follower guides provide an additional safety method to prevent buckling of the jack. Its assembly procedure is as follows.

1. Align the cylinder using the information shown previously
2. Install a follower guide on the head of the second biggest section of the jack
3. Repeat the same step for all sections with a smaller diameter
4. Install the car on the jack
5. Install a pair of shoes on each bracket
6. Install brackets on both sides of the follower guides
7. Run the jack up and down a few times
8. Make adjustments, if necessary

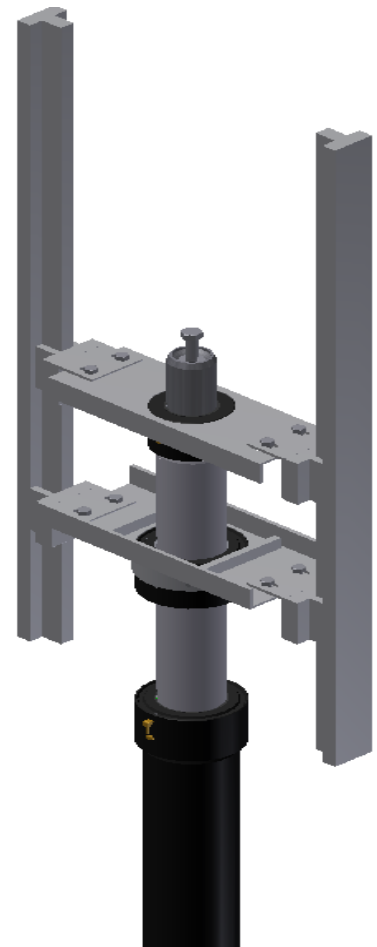

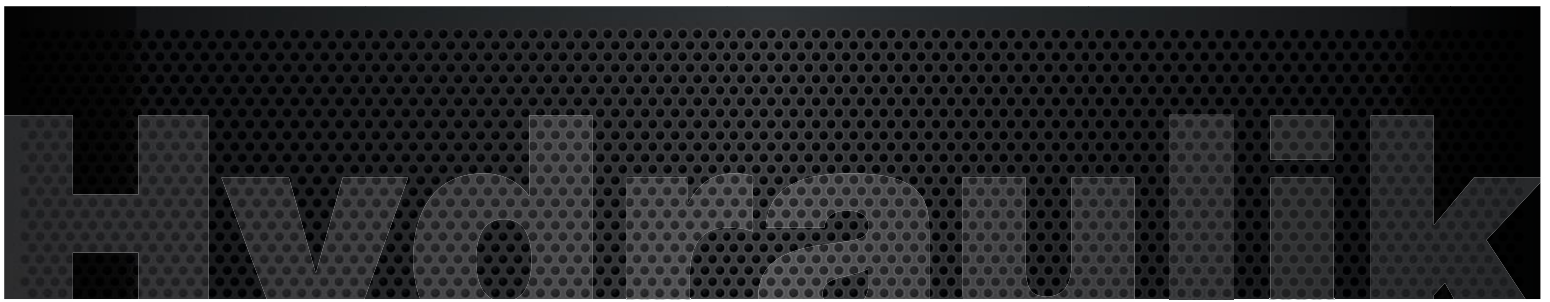

Twin jacks

Whenever two jacks are used for a single elevator, the oil inlet should divide into identical sections. Otherwise, the difference of friction (or restriction) between the sections could cause an unbalance of the loads between the cylinders. If for some reason, it is impossible to have identical paths, the use of an oil divider is to be considered. Increasing the diameter of the pipe used also helps.



Maintenance **program**

Monthly verification

- Verify the seals
- Verify the oil level
- Verify the oil quality
- Verify if there are leaks on the line

Note *If the seals need to be replaced often, the surface of the piston should be carefully inspected as it can be damaged, wearing the seals prematurely.*

Annual verification

- Verify the line strainers
- Verify the piston surface

Seal replacement

1. Lift the cabin up high enough to be able to remove the heads.
2. When the cabin is held securely, turn off the main switch.
3. Unscrew the bolts located above the piston.
4. Open the manual valve (gate valve) until the jack is completely collapsed; there should be no pressure in the jack.
5. Shut off the manual valve (gate valve) to the jack so the oil remains in the reservoir.
6. Open the bleeder on each head.
7. Disconnect the oil recuperator.
8. To facilitate the installation of the heads, mark with a pencil initial position of the head with a line on the head and on the piston.
9. Remove the heads by using two chain vise-grips.
10. Unscrew (CCW) the head while holding the piston with the other chain vise-grip.
11. It is important to put electric tape on the threads of the tubes to prevent damaging the seals when you put them in.
12. Unscrew the brass gland, remove the old joints, put the new ones and lubricate abundantly.
13. Screw back the gland to the maximum without letting any gap between the gland and the head.
14. Re-install the heads and tighten them up to the pencil mark.
15. Bleed the air in the jack, following the steps described in the venting the synchronized telescopic jack section shown previously
16. Re-install the hose to recuperate the oil on the straight or 90° coupling

Note *Pay special care to O'rings.*

Check valve **replacement**

The following is the general procedure to change the check valve. These instructions show a 2 sections telescopic jack but the procedure is the same no matter the number of sections.

1. Lift the car up to have enough space to remove the entire section of the jack.
2. When the car is held securely, close the main switches.
3. Unscrew the bolt that holds the piston to the car.
4. Open the manual valve until the piston is fully retracted. There should not be any pressure left in the jack.
5. Close the ball valve on the line leading to the jack to prevent any oil to come from the reservoir.
6. Install a chain block under the car, as centered as possible, and tie the chain around the head of the section where the replacement should be.
7. Remove the bleeder on the head just below and screw the 1/8" NPT fitting connected to a hose. While lifting the upper sections, oil will be ejected through this hose. You can recuperate it in a clean recipient.
8. Lift the previously tied section until the stopper ring reaches the head with the hose. Then, lower the sections of about one inch and unscrew this head. Once the head has been unscrewed, lift the sections until you have enough room to remove the check valve.
9. Remove the check valve by using a 15/16" or 3/4" socket. Some oil will come out this way; recuperate it in a clean recipient.



10. Install the new check valve and tighten it well.
11. Verify if the seals have not been damaged and replace them if it's necessary.
12. Insert the sections back in the cylinder and make sure that they are well centered. Screw back the head taken off previously as soon as possible for better alignment. There is no need to screw it very tight at this moment.
13. Just before the jack reaches a completely retracted position, unscrew the same head again to fill the jack with the recuperated oil. Then, screw the head firmly. Another option is simply to put the oil back in the power unit. Do not forget in this case to have the heads firmly screwed. Moreover, a pressure will have to be maintained on the piston to allow the oil to fill the jack.
14. Re-install the bleeder taken off previously.
15. Attach the piston to the car.
16. Follow the procedure described further to resynchronize the jack.

Warranty policy

GUARANTEE

1. ITI HYDRAULIK warrants to the original purchaser that this Product is free from any defects in materials or workmanship and agrees to repair or replace, in its sole discretion, any Product found to be defective during the period of **one year** from the date of delivery to the customer.
2. This warranty is only given to the original purchaser and comes into force on the delivery date of the Product.
3. The delivery date is the date of assumption of responsibility of the Product, ascertained by the bill of lading of the carrier.
4. Any part of this Product deemed, after reasonable evaluation by ITI HYDRAULIK, to be defective in workmanship or materials, will be repaired or replaced, free of charge for parts and labor, by ITI HYDRAULIK.

LIMITATION OF WARRANTY

5. This quality guarantee covers any defect in the manufacture or materials of the sold Product provided that:
 - (a) the Product is used for the purpose for which it is designed, intended and recommended by ITI HYDRAULIK;
 - (b) the Product has been installed and maintained by qualified personnel; and
 - (c) the maintenance recommended by ITI HYDRAULIK has been carried out by qualified personnel.
6. This warranty does not cover claims for damages, direct or indirect, for loss of time, or caused by a Product modification, Product tampering or Product adjustment made by or for the Buyer and not previously approved by ITI HYDRAULIK.
7. This warranty does not cover Product that has been damaged through abuse, neglected, lack of maintenance or failure to maintain the Product pursuant to the instructions in the user manual provided by ITI HYDRAULIK.
8. This warranty does not cover repairs necessitated by normal wear and tear of the Product or the use of unapproved parts and accessories with the Product or that are harmful to its proper functioning, performance or durability. In addition, this warranty excludes: consumable materials – hydraulic fluids, etc.
9. This warranty does not cover damage caused during transport, installation, maintenance or return of the Product. The Buyer shall promptly notify ITI HYDRAULIK in writing sent by mail, fax or registered mail when a defect is discovered, with a detailed explanation of the alleged defects. ITI HYDRAULIK will not assume and therefore will not pay any amount related to the elements mentioned above.
10. This warranty can not be relinquished, transferred or assigned to a third party; it is granted exclusively to the original purchaser of the Product. In the event that the Product is sold, transferred or otherwise disposed of, this warranty becomes void immediately for all legal purposes.

SUITABILITY OF THE PRODUCT

11. ITI HYDRAULIK complies with the manufacturing standards applicable to the Product sold. States and localities are governed by codes and regulations pertaining to construction, installation and use standards, which may differ from one region to another. ITI HYDRAULIK cannot be held responsible for the conformity of the Product with the application of these codes, standards, regulations; the Buyer is solely and exclusively responsible for this compliance before the confirmation of the order.

STORAGE OF THE PRODUCT

12. Storage of ITI HYDRAULIK products is not recommended for a period longer than 1 month; a horizontal position of the Product for a period of time greater than one month, may cause oil leakage. Any temporary storage requires a dry place, protected from theft, moisture, extreme heat and cold. Damage and defects caused by improper storage, stacking or handling are not covered by this warranty.

RETURNS OF MERCHANDISE

13. Any request to return the Product must be authorized prior to shipment by ITI HYDRAULIK Technical Services. Following an authorization from ITI HYDRAULIK, a return number is assigned and must be indicated on the outer packaging of the Product return packaging. The same packing criteria as at the original packing receipt must be utilized. The customer is responsible for transporting the return of the Product to the specified ITI HYDRAULIK factory. A Product found to be defective after inspection by ITI HYDRAULIK may, in our sole discretion, be repaired or replaced at no charge. A credit request for any product return must be authorized by ITI HYDRAULIK and is subject to a 35% restocking fee, plus initial shipping costs.

TECHNICAL SERVICE

14. ITI HYDRAULIK provides free installation manuals on its website and technical assistance on its Products. This information is intended for people with knowledge and skills in this area who will use it at their own risk. ITI HYDRAULIK assumes no liability for damage caused by anyone using these manuals.

PRICES OF PRODUCTS

15. Product prices are subject to change without notice.

FORCE MAJEURE

16. From the date of delivery, the buyer assumes all liability and costs inherent to the Product. ITI HYDRAULIK shall not be considered in default in the performance of its obligations hereunder if such performance is delayed, withheld or prevented as a result of a fortuitous event or force majeure. Force majeure is any cause that ITI HYDRAULIK could not reasonably have foreseen and against which it could not have protected itself. Force majeure includes, but is not limited to, any fortuitous event, injury, illness, accident, death, destruction of property, use of the Product sold, natural disaster, strike, partial or complete stoppage of work, lockout, fire, riot, intervention by civil or military authorities, acquiescence with the regulations or orders of any governmental authority and warfare (declared or not).

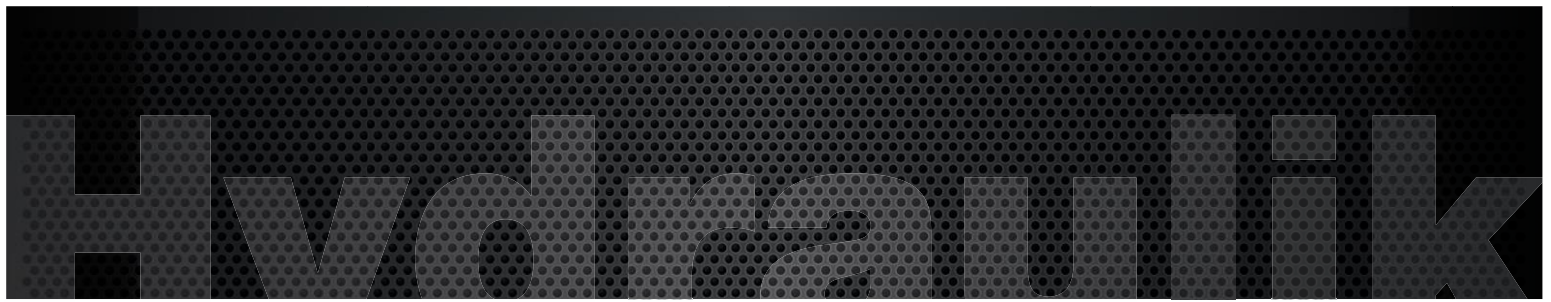

PRIORITY CLIENT

Since 20 years, the ITI engineers had access to tools and to state-of-the-art formations of the industry. It is this continues training that allows us to provide you with quality products that will meet your needs. Furthermore, we are the leaders regarding delivery deadlines.



3611 ROUTE 346, SAINTE-JULIENNE (QUÉBEC) J0K 2T0
TELEPHONE : 450-831-3229 | FAX : 450-831-2219 | TOLL FREE : 1-800-953-3229 | E-MAIL : INFO@ITIHYDRAULIK.COM

WWW.ITIHYDRAULIK.COM